

WEB SITE: www.simulate-events.com

Technical Note No.51

Subject: **Light truck crashing against portable concrete barrier.**

The truck model itself is shown in Fig.1. The road, on which it moves is not visualized, The barrier is an item frequently seen along roads. (Height: 0.79m, length: 3.05m.)

Two impact velocities are simulated, 15 m/s (or 54 km/h), medium speed, and 25m/s (or 90 km/h), high speed.The next three figures, 2,3 and 4 show the sequence of collision with a medium speed. (An angle view from above, then side view.) The underside is severely damaged and the barrier overturned.

The remaining figures show the high-speed collision (90 km/h) effects. This time the front underside is completely squashed and the barrier changed into rubble. In both cases the front of the truck becomes airborne.

DETAILS

The original model of this truck was created by NCAP. We have extensively modified it, especially with regard to material properties, to enable execution of this work. The mass of the truck is 1878 kg and the barrier is somewhat heavier. In the first impact the forward speed decreases from 15 to about 6 m/s. In the second the reduction is from 25 to 15 m/s.

The following are the average horizontal accelerations.

For $v=54$ km/h, $a = 13.3g$

For $v=90$ km/h, $a = 17.7g$

where 'g' is the acceleration of gravity.

PICKUP TRUCK MODEL

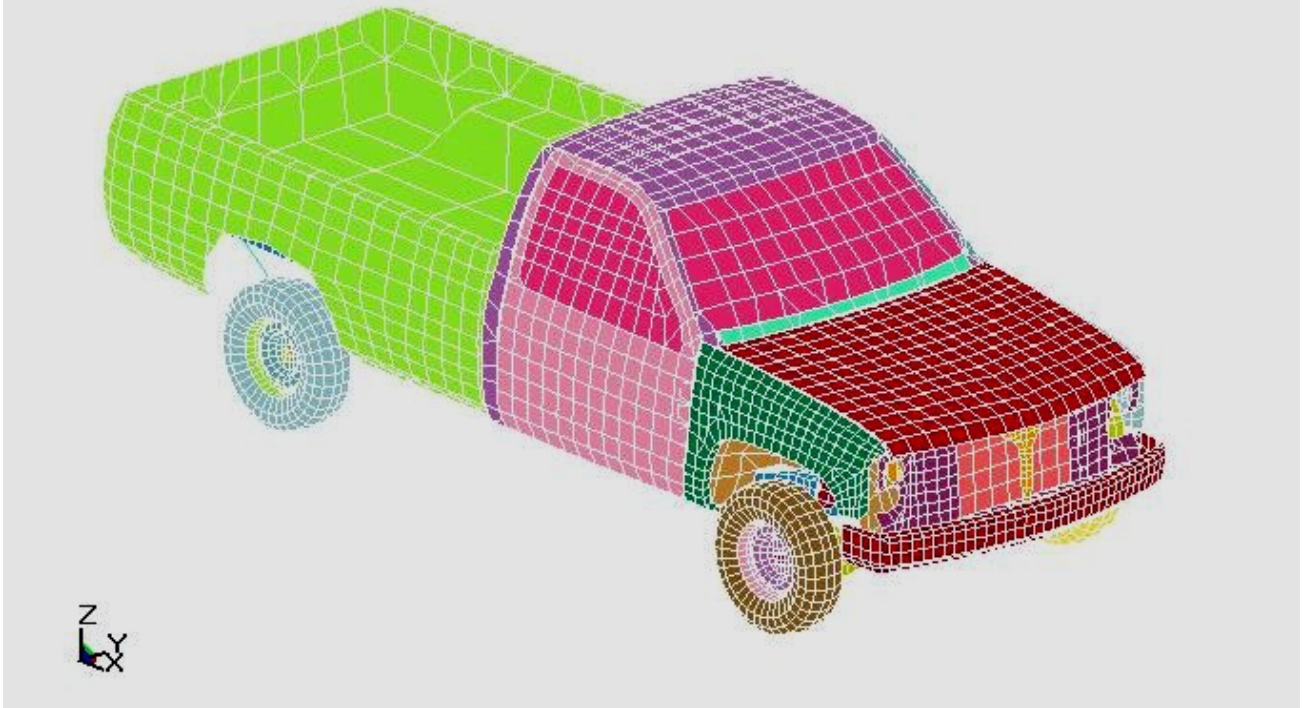

Fig.1. Light truck model

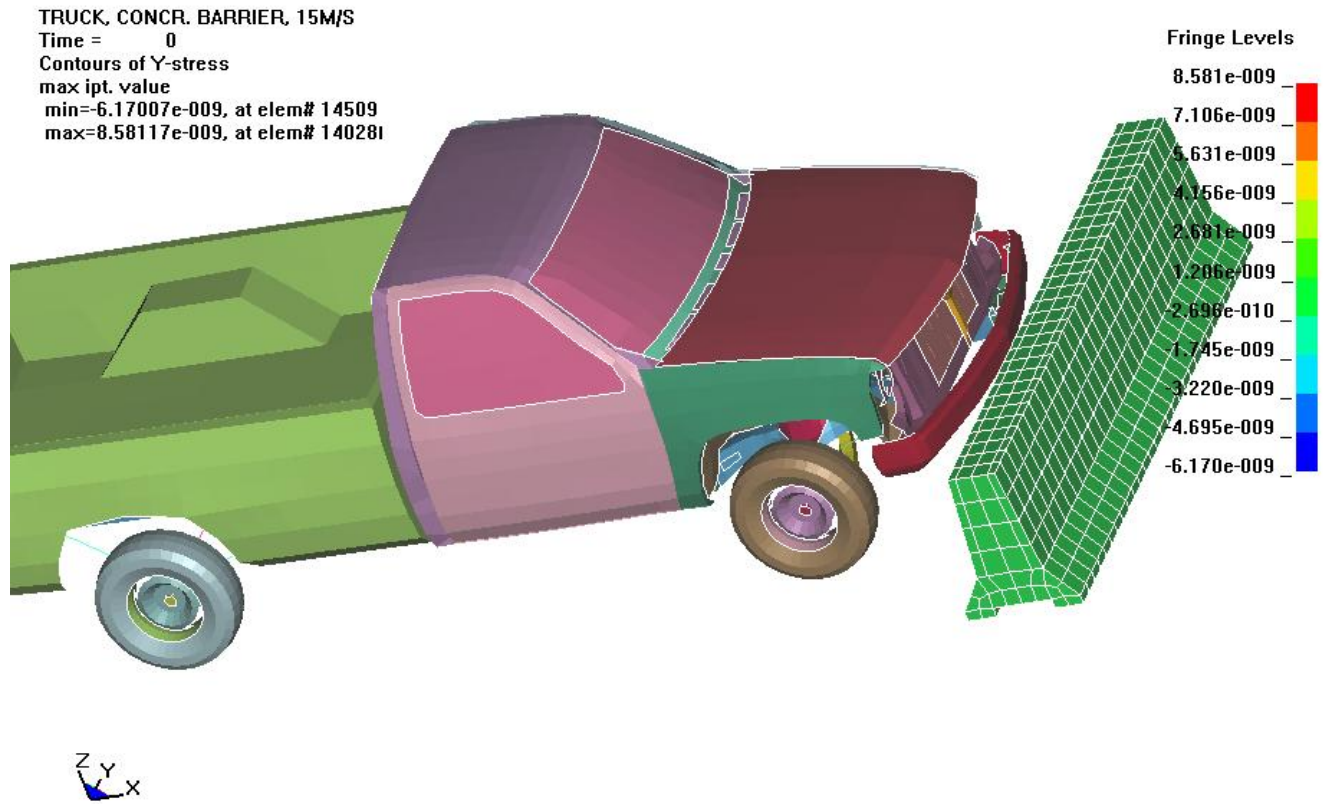

Fig.2 Medium speed, before contact.

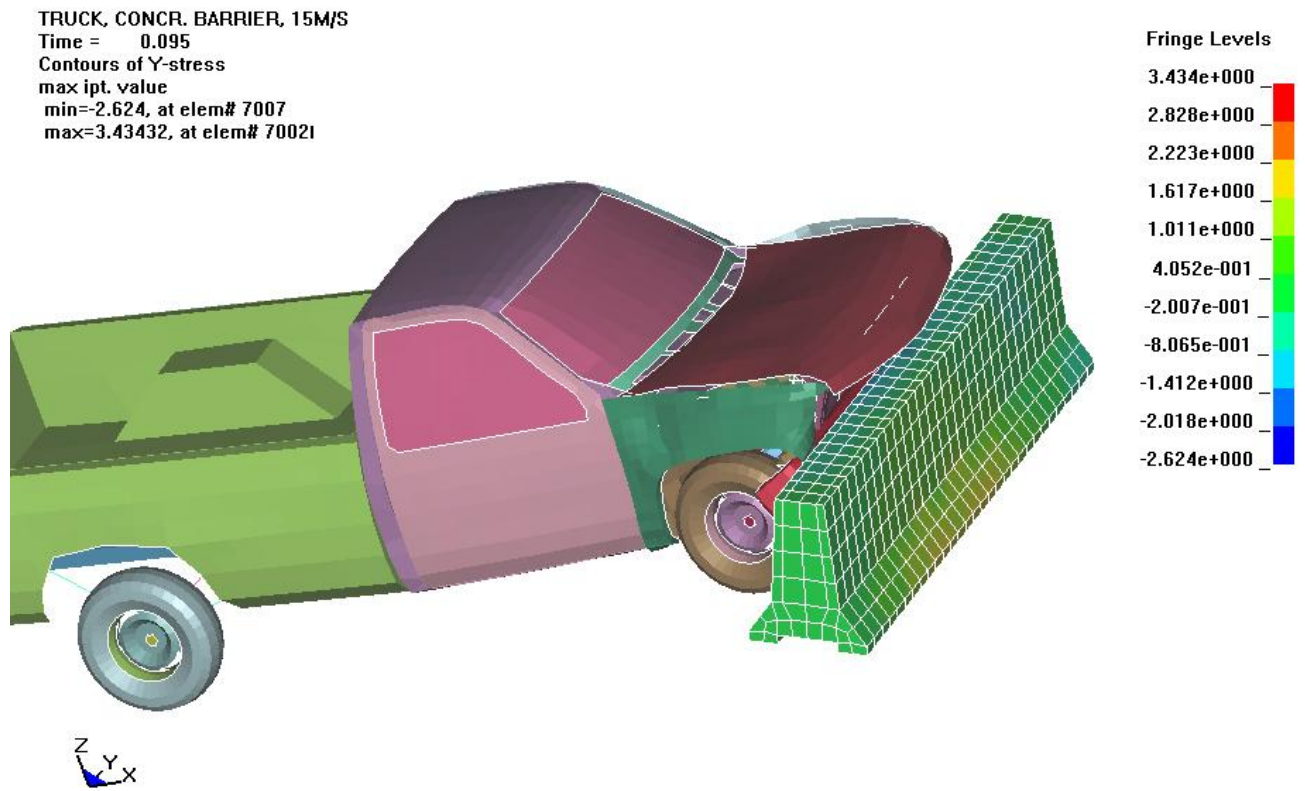

Fig.3 Medium speed, initial impact.

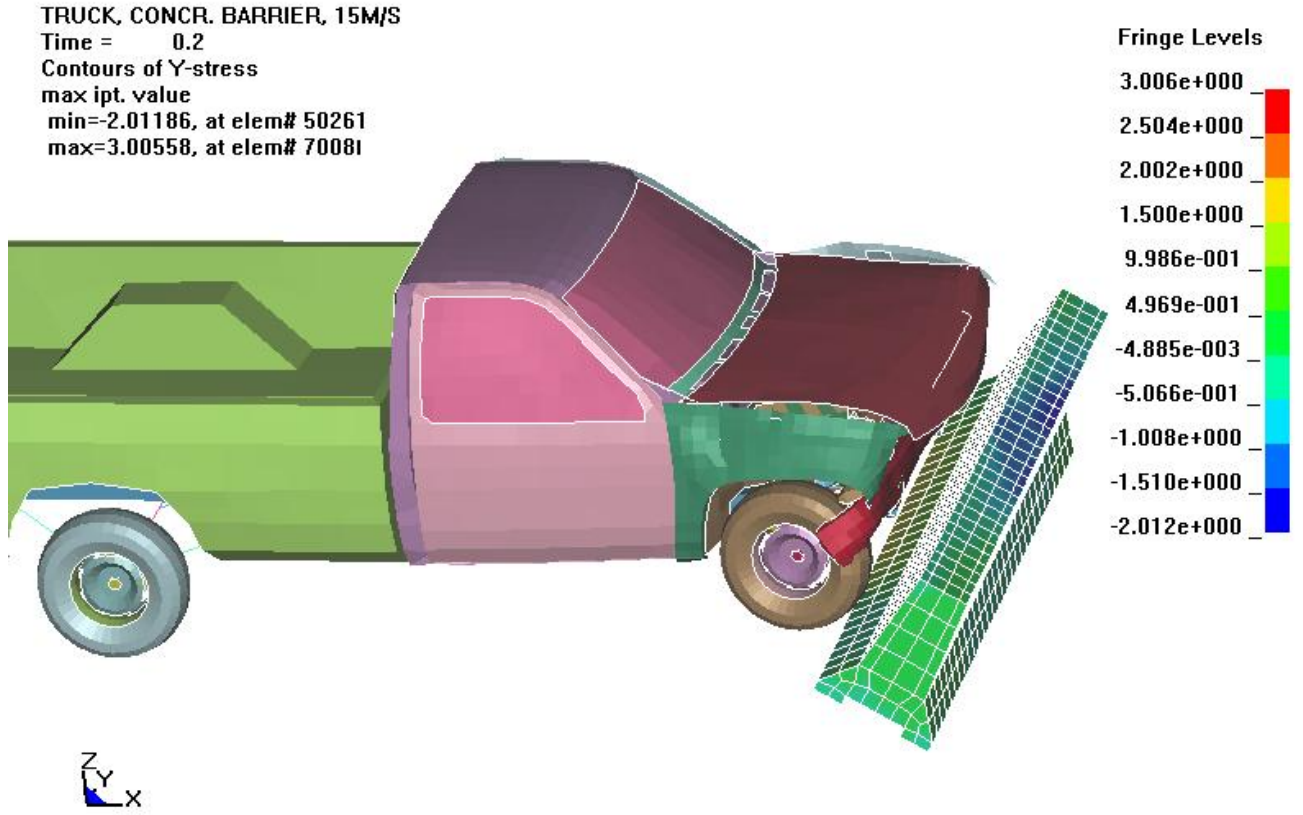

Fig.4 Medium speed, barrier overturned

TRUCK, CONCR. BARR, 25M/S
Time = 0.025

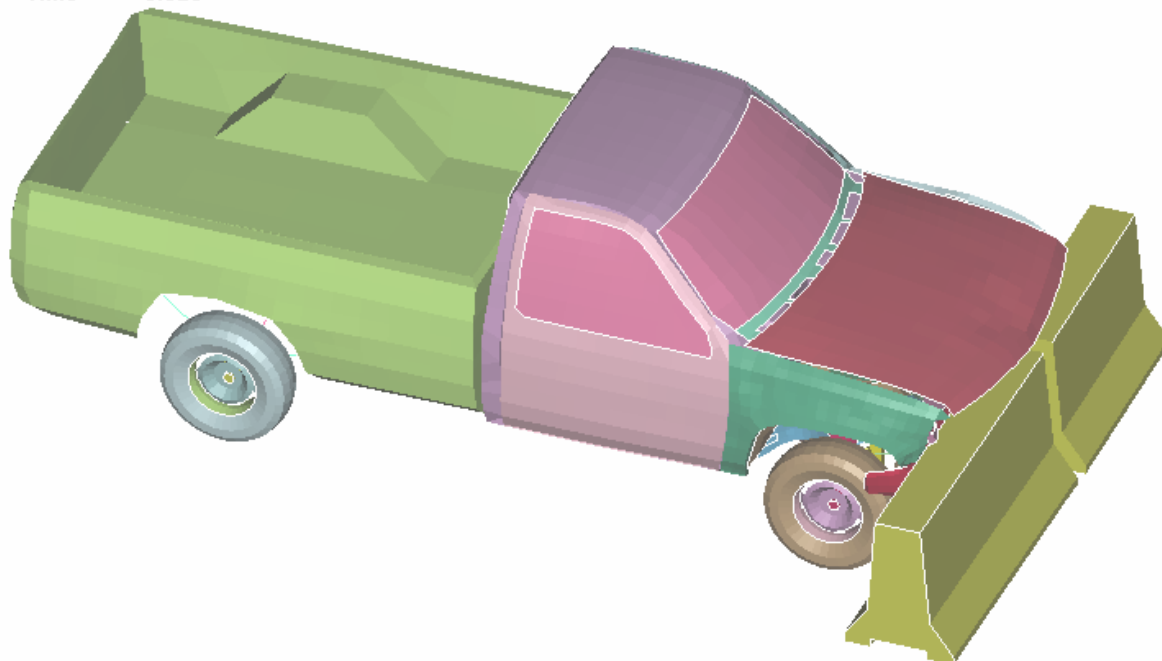

Fig.5 High speed, initial impact, barrier cracked.

TRUCK, CONCR. BARR, 25M/S
Time = 0.054999

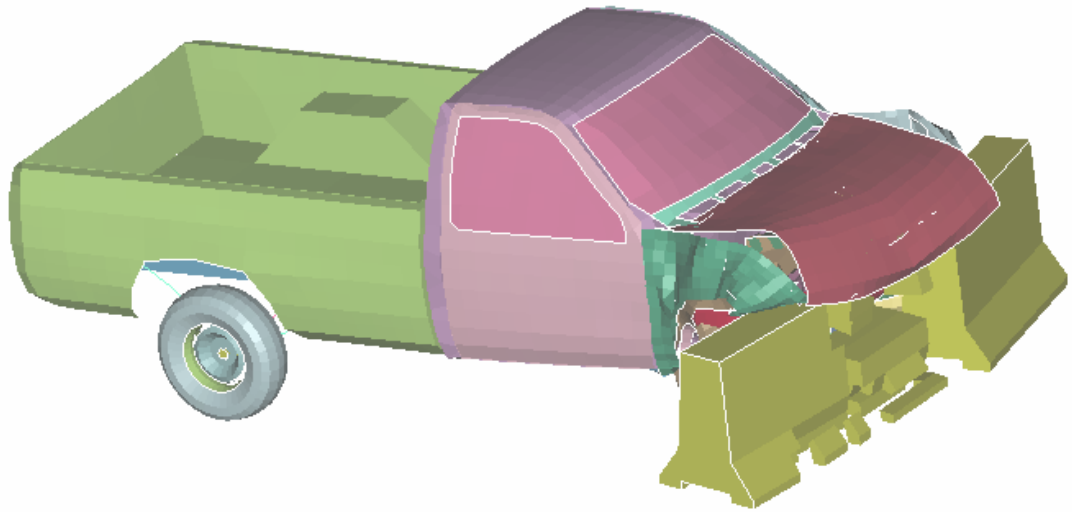

Fig.6 High speed, initial impact, barrier disintegrating.

TRUCK, CONCR. BARR, 25M/S
Time = 0.18

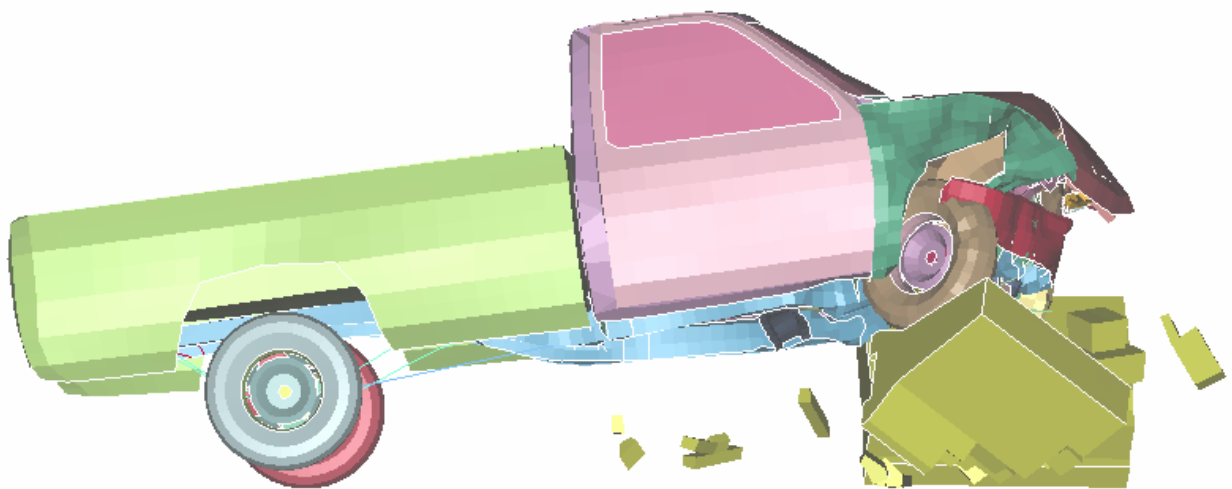

Fig.7 High speed, side view, barrier broken and overturned, front end airborne.